



DIGITAL PRESSURE GAUGES

MODEL: DPG-100LM

SPECIFICATIONS

The DPG-100 Digital Pressure Gauges with 1% full scale accuracy uses FTB-developed and patented technology as your cutting edge, cost-effective provider for digital solutions. The FTB-developed technology delivers stable and long-lasting performance. 5 1/2 digits white backlight LCD makes DPG-100 easy to read. The DPG-100 was built for the applications which the cost for digital solutions is highly concerned.



GENERAL CHARACTERISTICS

NOMINAL DIAMETERS (mm) 100 (DN100)
PROCESS CONNECTION Standard Brass 1/2" PT
 SS316 Optional

ACCURACY
 ±1,0% F.S. Accuracy

CASE
 Chrome-Plated Steel Case

AMBIENT TEMPERATURE
 -10...+75°C

STORAGE TEMPERATURE
 -10...+50°C

WINDOW
 5 1/2 digits white backlight LCD

POWER REQUIREMENT
 24 VDC

RANGES
 Vacuum, Compound, and upto 1000 kg

ENGINEERING UNITS
 Negative/Vacuum (kg/cm², bar, "Hg, cmHg, mmHg), Positive (bar, psi, kg/cm², MPa, kPa), Compound (kg/cm², bar, "Hg, cmHg, mmHg)

ANALOG OUTPUTS
 0-5/10 VDC

NPN/PNP CONTACTS
 8 Editable Contacts
 (NO/NC/OFF)

SERIAL COMMUNICATION
 RS-485 Optional

DIMENSIONS

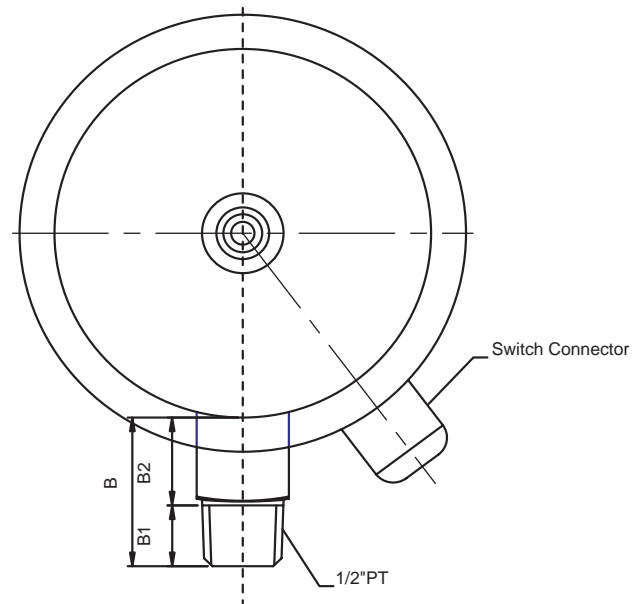

型號	D	D1	D2	D3	B	B1	B2	S	S1	S2	S3	R	G	H
DPG-100LM					34	16	18							

